



EXTRACTORES HELICOIDALES MURALES

SERIE COMPACT HCFT/HCFB

Ventiladores axiales murales con hélice de plástico reforzada con fibra de vidrio, motor monofásico (HCFB) o trifásico (HCFT), IP65 (Modelos 800,900 y 1.000 IP55). Clase F, protector térmico incorporado y caja de bornes ignífuga VO, con condensador incorporado en los modelos monofásicos. Motores de 2, 4, 6 u 8 polos, según versiones. Regulables excepto modelos de 2 polos y 4/630, 4/710, 800, 900 y 1.000. Sentido del aire Motor-Helice (flujo A). Helice-Motor (flujo B) y modelos trifásicos regulables mediante variador de frecuencia bajo demanda."

TRIFÁSICOS 230/400V-50Hz ó 400V-50Hz.

Código	Modelo	€	Velocidad r.p.m.	Ø boca (mm)	Potencia absorbida máxima (W)	Intensidad máxima (A)		Presión sonora (dB(A))	Caudal máximo m³/h.	Peso Kg.
						a 230 V.	a 400 V.			
MV4001	HCFT/4-250/H	291,67	1.330	250	60	0,3	0,2	52	1.220	5
MV4003	HCFT/4-315/H	292,22	1.300	315	150	0,6	0,3	54	2.350	7
MV4005	HCFT/4-355/H	385,50	1.260	355	200	0,8	0,5	58	3.490	8
MV4007	HCFT/4-400/H	415,69	1.350	400	300	1,4	0,8	60	5.070	9
MV4009	HCFT/4-450/H	536,56	1.230	450	500	1,7	1,0	65	6.760	13
MV4012	HCFT/4-500/H	645,23	1.350	500	660	2,7	1,6	68	9.200	16

MONOFÁSICOS 230 V. 50 Hz.

Código	Modelo	€	Velocidad r.p.m.	Ø boca (mm)	Potencia absorbida máxima (W)	Intensidad máxima (A)		Presión sonora (dB(A))	Caudal máximo m³/h.	Peso Kg.
						a 230 V.	a 400 V.			
MV4051	HCFB/4-250/H	312,80	1.330	250	60	0,3		52	1.215	5
MV4053	HCFB/4-315/H	323,97	1.300	315	100	0,6		54	2.350	7
MV4055	HCFB/4-355/H	413,53	1.225	355	200	1,0		58	3.490	8
MV4057	HCFB/4-400/H	440,73	1.200	400	340	1,6		60	5.070	9
MV4059	HCFB/4-450/H	559,22	1.290	450	480	2,3		65	6.760	13
MV4062	HCFB/4-500/H	684,36	1.290	500	650	3,0		68	9.200	16

DIMENSIONES mm.

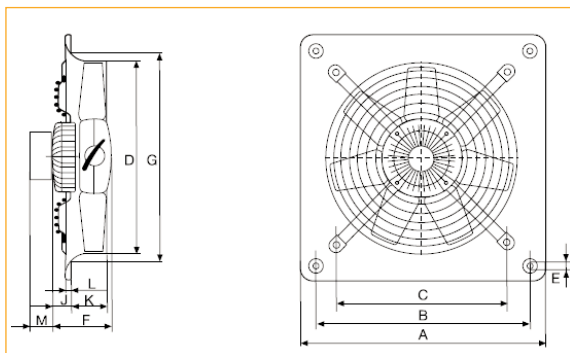

Tipo	A	B	C	Ø D	Ø E	F 4 Polos	Ø G	J 4 Polos	K	L	M	
											Trifásico	Mono
250	315	260	220	254	10	122	294	59	53	12	40	65
315	400	330	280	315	10	122	329	32	68	12	40	65
355	450	380	315	355	10	129	371	45	75	12	40	65
400	500	420	355	400	10	129	422	40,5	78	12	40	65
450	560	480	400	450	10	150	476	48	91	12	40	65
500	630	560	450	500	10	150	536	44,5	97	12	40	65



EXTRACTORES HELICOIDALES MURALES

SERIE HXM

Ventiladores axiales murales de acero galvanizado, protegidos con pintura poliéster anticorrosiva. Motor monofásico 230 V-50Hz. de espira de sombra, en aluminio inyectado, regulable. IP40. Clase B, con cable de conexión incorporado y motor montado sobre cojinetes de fricción autolubricados. Modelo HXM-400: Motor de rotor exterior, IP44, Clase F, con rodamientos a bolas, protector térmico de rearme automático y caja de bornes ifnifuga con condensador. Sin cable de conexión incorporado. Sentido del aire Motor-Helice (Flujo A).

TRIFÁSICOS 230/400V-50Hz ó 400V-50Hz.

Código	Modelo	€	Velocidad r.p.m.	Ø boca (mm)	Potencia absorbida máxima (W)	Intensidad máxima absorbida (A)	Presión sonora (dB(A))	Caudal máximo m³/h.	Peso Kg.
MV3060	HXM-200	117,57	1.300	200	30	0,22	36	500	1,7
MV3061	HXM-250	142,35	1.300	250	40	0,30	42	900	2,5
MV3062	HXM-300	167,63	1.300	300	60	0,45	48	1.400	3,1
MV3063	HXM-350	227,85	1.300	350	60	0,45	53	1.800	4,4
MV3064	HXM-400	344,71	1.300	400	200	1,60	57	3.000	7,3

DIMENSIONES mm.

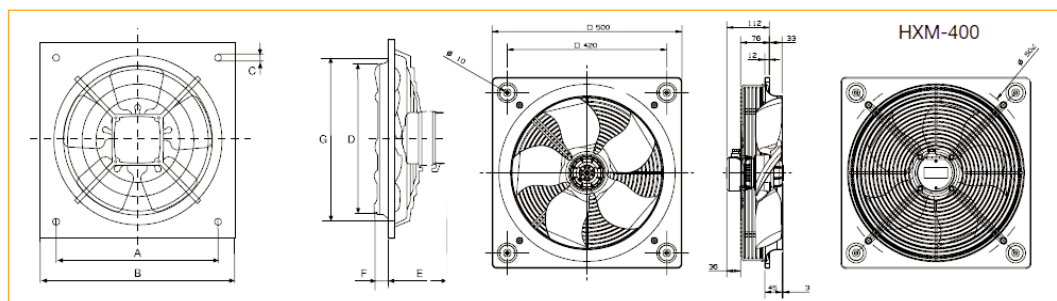

Tipo	A	B	ØC	ØD	E	F	ØG
HXM-200	222	266	9	205	85,5	19	211
HXM-250	275,5	333	9	255	92,5	31	261
HXM-300	336,5	400	10,5	305	92,5	35,5	311
HXM-350	390	465	10,5	361	105,5	34,5	371
HXM-400	VER DIBUJO						



EXTRACTORES HELICOIDALES MURALES

SERIE HXTR/HXBR

Ventiladores axiales murales con hélice "Sickle" equilibrada en dos planos, de bajo nivel sonoro, protegidos contra la corrosión mediante tratamiento por cataforesis y pintados con poliéster. Motor de rotor exterior, IP54, Clase F con protector térmico incorporado y caja de bornes ignífuga V0 con condensador incorporado en los modelos monofásicos. Motores de 2, 4, 6, 8 ó 12 polos, según versiones. Regulables, excepto modelo HXBR/4-630 y Ø de 710 a 1.000. Sentido del aire Motor-Hélice (flujo A), bajo demanda Hélice-Motor (flujo B).

TRIFÁSICOS 230/400 V. 50 Hz. Hasta Ø 1.000 mm.

Código	Modelo	€	Velocidad r.p.m.	Ø boca (mm)	Potencia absorbida máxima (W)	Intensidad máxima (A)		Presión sonora (dB(A))	Caudal máximo m³/h.	Peso Kg.
						a 230 V.	a 400 V.			
MV4081	HXTR/4-250	180,37	1.450	250	50	0,35	0,20	46	930	6,5
MV4082	HXTR/4-315	213,05	1.420	315	130		0,46	53	2.074	7,0
MV4083	HXTR/4-355	283,77	1.400	355	150		0,42	59	2.970	7,5
MV4084	HXTR/4-400	330,43	1.340	400	300		0,80	60	5.080	9,0
MV4086	HXTR/4-450	413,63	1.340	450	570		1,10	64	7.649	11,5
MV4088	HXTR/4-500	484,95	1.370	500	970		1,90	69	9.957	16,0

MONOFÁSICOS 230 V. 50 Hz. Hasta Ø 710 mm.

Código	Modelo	€	Velocidad r.p.m.	Ø boca (mm)	Potencia absorbida máxima (W)	Intensidad máxima (A)		Presión sonora (dB(A))	Caudal máximo m³/h.	Peso Kg.
						a 230 V.	a 400 V.			
MV4111	HXBR/4-250	200,21	1.450	250	40	0,21		46	930	6,5
MV4112	HXBR/4-315	232,88	1.400	315	120	0,53		53	2.074	7,0
MV4113	HXBR/4-355	296,03	1.400	355	120	0,55		59	2.970	7,5
MV4114	HXBR/4-400	349,75	1.360	400	290	1,20		60	5.080	9,0
MV4116	HXBR/4-450	433,55	1.360	450	530	2,00		64	7.649	11,5
MV4118	HXBR/4-500	514,17	1.350	500	850	3,80		69	9.957	16,0

DIMENSIONES mm.

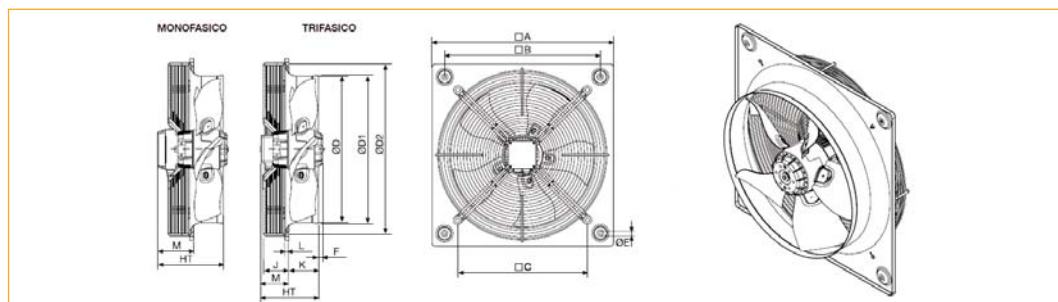

Tipo	A	B	C	Ø D	Ø D1	Ø D2	E	F		HT		J	K	L	M	
								I	III	I	III				I	III
250	315	260	220	250	261	290	10	0	0	126	126	33	53	12	73	73
315	400	330	280	315	320	365	10	0	0	149	149	41	68	12	82	82
355	450	380	315	355	363	411	10	0	0	156	156	41	75	12	82	82
400	500	420	355	400	410	464	10	12	0	200	176	92	78	12	122	97
450	560	480	400	450	457	522	10	0	0	204	179	68	91	12	114	89
500	630	560	450	500	512	572	10	13	13	201	176	60	97	12	104	79