

**EVAPORADORES INDUSTRIALES DE PLAFÓN - SERIE TT Ø 630**
**PASO DE ALETAS: 4,2 mm.**
**R-404A**

Modelo		TTM 2440	TTM 3000	TTM 3700	TTM 4700	TTM 6000
0 Pa - Capacidad $\Delta T_1 = 8K-W$ (ENV 328 cond. 2)		38.080	49.360	57.120	74.040	98.720
Caudal de aire	m <sup>3</sup> /h	32.500	31.400	48.750	47.100	62.800
150 Pa*-Capacidad $\Delta T_1 = 8K-W$ (ENV 328 cond. 2)		33.120	42.160	49.680	63.240	84.320
Caudal de aire	m <sup>3</sup> /h	24.800	24.000	37.200	36.000	48.000
Superficie	m <sup>2</sup>	218	327	327	491	654
Volumen interior	dm <sup>3</sup>	42	63	62	93	123
Motoventiladores 400VIII/50Hz 1.300 r.p.m.	Nº x Ø	2 x 630	2 x 630	3 x 630	3 x 630	4 x 630
	A	6,20	6,20	9,30	9,30	12,40
	kW	3,70	3,70	5,55	5,55	7,40
Desescarche Eléctrico	Bandeja num.	2	2	2	2	2
	Batería num.	6	10	6	10	10
	Total	8	12	8	12	12
	Potencia W	16.000	24.000	24.000	36.000	48.000
Conexiones mm.	Entrada	22	28	28	2x22	2x28
	Salida	54	66	66	2x54	2x66
Peso neto	Kg.	243	303	347	435	568
Sin Desescarche	€	8.435	10.030	11.920	13.560	18.010
	Código	EV6450	EV6451	EV6452	EV6453	EV6454
Desescarche Eléctrico	€	8.972	10.800	12.615	14.556	19.158
	Código	EV6460	EV6461	EV6462	EV6463	EV6464

**PASO DE ALETAS: 7 mm.**
**R-404A**

Modelo		TTB 1650	TTB 2350	TTB 2800	TTB 3800	TTB 5250
0 Pa - Capacidad $\Delta T_1 = 8K-W$ (ENV 328 cond. 2)		32.160	43.040	48.240	64.560	86.080
Caudal de aire	m <sup>3</sup> /h	33.800	32.800	50.700	49.200	65.600
150 Pa*-Capacidad $\Delta T_1 = 8K-W$ (ENV 328 cond. 2)		27.920	37.120	41.880	55.680	74.240
Caudal de aire	m <sup>3</sup> /h	25.600	25.200	38.400	37.800	50.400
Superficie	m <sup>2</sup>	137	205	205	307	410
Volumen interior	dm <sup>3</sup>	42	63	62	93	123
Motoventiladores 400VIII/50Hz 1.300 r.p.m.	Nº x Ø	2 x 630	2 x 630	3 x 630	3 x 630	4 x 630
	A	6,20	6,20	9,30	9,30	12,40
	kW	3,70	3,70	5,55	5,55	7,40
Desescarche Eléctrico	Bandeja num.	2	2	2	2	2
	Batería num.	6	10	6	10	10
	Total	8	12	8	12	12
	Potencia W	16.000	24.000	24.000	36.000	48.000
Conexiones mm.	Entrada	22	28	28	2x22	2x28
	Salida	54	66	66	2x54	2x66
Peso neto	Kg.	228	281	325	401	523
Sin Desescarche	€	8.295	9.820	11.710	13.250	17.600
	Código	EV6470	EV6471	EV6472	EV6473	EV6474
Desescarche Eléctrico	€	8.832	10.590	12.405	14.246	18.748
	Código	EV6480	EV6481	EV6482	EV6483	EV6484

150 Pa\* - Pérdida de carga del aire en la cámara.

La capacidad indicada corresponde a la potencia sensible del evaporador (superficie seca).

**EVAPORADORES INDUSTRIALES DE PLAFÓN - SERIE TT Ø 630**
**PASO DE ALETAS: 9 mm.**
**R-404A**

Modelo		TTL 1500	TTL 2150	TTL 2500	TTL 3600	TTL 5050
0 Pa - Capacidad $\Delta T_1 = 8K-W$ (ENV 328 cond. 2)		28.960	39.360	43.440	59.040	78.720
Caudal de aire	m <sup>3</sup> /h	34.200	33.400	51.300	50.100	66.800
150 Pa*-Capacidad $\Delta T_1 = 8K-W$ (ENV 328 cond. 2)		25.200	34.000	37.800	51.000	68.000
Caudal de aire	m <sup>3</sup> /h	26.000	25.600	39.000	38.400	51.200
Superficie	m <sup>2</sup>	109	164	164	246	328
Volumen interior	dm <sup>3</sup>	42	63	62	93	123
Motoventiladores 400V/III/50Hz 1.300 r.p.m.	Nº x Ø	2 x 630	2 x 630	3 x 630	3 x 630	4 x 630
	A	6,20	6,20	9,30	9,30	12,40
	kW	3,70	3,70	5,55	5,55	7,40
Desescarche Eléctrico	Bandeja num.	2	2	2	2	2
	Batería num.	6	10	6	10	10
	Total	8	12	8	12	12
	Potencia W	16.000	24.000	24.000	36.000	48.000
Conexiones mm.	Entrada	22	28	28	2x22	2x28
	Salida	54	66	66	2x54	2x66
Peso neto	Kg.	219	266	309	380	494
Sin Desescarche	€	<b>8.215</b>	<b>9.700</b>	<b>11.590</b>	<b>13.070</b>	<b>17.360</b>
	Código	EV6490	EV6491	EV6492	EV6493	EV6494
Desescarche Eléctrico	€	<b>8.752</b>	<b>10.470</b>	<b>12.285</b>	<b>14.066</b>	<b>18.508</b>
	Código	EV6500	EV6501	EV6502	EV6503	EV6504

**PASO DE ALETAS: 12 mm.**
**R-404A**

Modelo		TTX 1250	TTX 1750	TTX 2000	TTX 2900	TTX 4000
0 Pa - Capacidad $\Delta T_1 = 8K-W$ (ENV 328 cond. 2)		23.840	33.040	35.760	49.560	66.080
Caudal de aire	m <sup>3</sup> /h	34.200	33.500	51.300	50.250	67.000
150 Pa*-Capacidad $\Delta T_1 = 8K-W$ (ENV 328 cond. 2)		20.960	28.720	31.440	43.080	57.440
Caudal de aire	m <sup>3</sup> /h	26.000	25.500	39.000	38.250	51.000
Superficie	m <sup>2</sup>	103	154	154	231	308
Volumen interior	dm <sup>3</sup>	53	79	78	117	154
Motoventiladores 400V/III/50Hz 1.300 r.p.m.	Nº x Ø	2 x 630	2 x 630	3 x 630	3 x 630	4 x 630
	A	6,20	6,20	9,30	9,30	12,40
	kW	3,70	3,70	5,55	5,55	7,40
Desescarche Eléctrico	Bandeja num.	2	2	2	2	2
	Batería num.	6	10	6	10	10
	Total	8	12	8	12	12
	Potencia W	16.000	24.000	24.000	36.000	48.000
Conexiones mm.	Entrada	22	22	28	28	2x22
	Salida	54	54	66	66	2x54
Peso neto	Kg.	223	273	317	390	508
Sin Desescarche	€	<b>8.330</b>	<b>9.765</b>	<b>11.830</b>	<b>13.730</b>	<b>17.480</b>
	Código	EV6510	EV6511	EV6512	EV6513	EV6514
Desescarche Eléctrico	€	<b>8.867</b>	<b>10.535</b>	<b>12.525</b>	<b>14.726</b>	<b>18.628</b>
	Código	EV6520	EV6521	EV6522	EV6523	EV6524

150 Pa\* - Pérdida de carga del aire en la cámara.

La capacidad indicada corresponde a la potencia sensible del evaporador (superficie seca).

**EVAPORADORES INDUSTRIALES DE PLAFÓN - SERIE TT Ø 710**
**PASO DE ALETAS: 4,2 mm.**
**R-404A**

Modelo		TTM 2550	TTM3850	TTM 4400	TTM 5200	TTM 7600
0 Pa - Capacidad $\Delta T_1 = 8K-W$ (ENV 328 cond. 2)		45.280	60.080	67.920	90.120	120.160
Caudal de aire	m <sup>3</sup> /h	46.600	45.000	69.900	67.500	90.000
250 Pa*-Capacidad $\Delta T_1 = 8K-W$ (ENV 328 cond. 2)		38.880	49.920	58.320	74.880	99.840
Caudal de aire	m <sup>3</sup> /h	33.800	32.000	50.700	48.000	64.000
Superficie	m <sup>2</sup>	218	327	327	491	654
Volumen interior	dm <sup>3</sup>	42	63	62	93	123
Motoventiladores 400V/III/50Hz 1.300 r.p.m.	Nº x Ø	2 x 710	2 x 710	3 x 710	3 x 710	4 x 710
	A	16,4	16,4	24,6	24,6	32,8
	kW	8	8	12	12	16
Desescarche Eléctrico	Bandeja num.	2	2	2	2	2
	Batería num.	6	10	6	10	10
	Total	8	12	8	12	12
	Potencia W	16.000	24.000	24.000	36.000	48.000
Conexiones mm.	Entrada	22	28	28	2x28	2x28
	Salida	54	66	66	2x66	2x66
Peso neto	Kg.	313	382	463	561	720
Sin Desescarche	€	<b>11.490</b>	<b>12.980</b>	<b>16.350</b>	<b>18.310</b>	<b>23.910</b>
	Código	<b>EV6530</b>	<b>EV6531</b>	<b>EV6532</b>	<b>EV6533</b>	<b>EV6534</b>
Desescarche Eléctrico	€	<b>12.027</b>	<b>13.750</b>	<b>17.045</b>	<b>19.306</b>	<b>25.058</b>
	Código	<b>EV6540</b>	<b>EV6541</b>	<b>EV6542</b>	<b>EV6543</b>	<b>EV6544</b>

**PASO DE ALETAS: 7 mm.**
**R-404A**

Modelo		TTB 2100	TTB 3100	TTB 3350	TTB 4800	TTB 6100
0 Pa - Capacidad $\Delta T_1 = 8K-W$ (ENV 328 cond. 2)		38.320	52.160	57.480	78.240	104.320
Caudal de aire	m <sup>3</sup> /h	48.800	47.400	73.200	71.100	94.800
250 Pa*-Capacidad $\Delta T_1 = 8K-W$ (ENV 328 cond. 2)		33.200	44.320	49.800	66.480	88.640
Caudal de aire	m <sup>3</sup> /h	36.000	34.600	54.000	51.900	69.200
Superficie	m <sup>2</sup>	137	205	205	307	410
Volumen interior	dm <sup>3</sup>	42	63	62	93	123
Motoventiladores 400V/III/50Hz 1.300 r.p.m.	Nº x Ø	2 x 710	2 x 710	3 x 710	3 x 710	4 x 710
	A	16,4	16,4	24,6	24,6	32,8
	kW	8	8	12	12	16
Desescarche Eléctrico	Bandeja num.	2	2	2	2	2
	Batería num.	6	10	6	10	10
	Total	8	12	8	12	12
	Potencia W	16.000	24.000	24.000	36.000	48.000
Conexiones mm.	Entrada	22	28	28	2x28	2x28
	Salida	54	66	66	2x66	2x66
Peso neto	Kg.	298	360	441	527	675
Sin Desescarche	€	<b>11.350</b>	<b>12.770</b>	<b>16.140</b>	<b>18.000</b>	<b>23.500</b>
	Código	<b>EV6550</b>	<b>EV6551</b>	<b>EV6552</b>	<b>EV6553</b>	<b>EV6554</b>
Desescarche Eléctrico	€	<b>11.887</b>	<b>13.540</b>	<b>16.835</b>	<b>18.996</b>	<b>24.648</b>
	Código	<b>EV6560</b>	<b>EV6561</b>	<b>EV6562</b>	<b>EV6563</b>	<b>EV6564</b>

250 Pa\* - Pérdida de carga del aire en la cámara.

La capacidad indicada corresponde a la potencia sensible del evaporador (superficie seca).

**EVAPORADORES INDUSTRIALES DE PLAFÓN - SERIE TT Ø 710**

PASO DE ALETAS: 9 mm.

**R-404A**

Modelo		TTL 1700	TTL 2650	TTL 2850	TTL 4200	TTL 5800
0 Pa - Capacidad $\Delta T_1 = 8K-W$ (ENV 328 cond. 2)		34.480	47.520	51.720	71.280	95.040
Caudal de aire	m <sup>3</sup> /h	49.600	48.200	74.400	72.300	96.400
250 Pa*-Capacidad $\Delta T_1 = 8K-W$ (ENV 328 cond. 2)		30.240	40.880	45.360	61.320	81.760
Caudal de aire	m <sup>3</sup> /h	37.400	36.000	56.100	54.000	72.000
Superficie	m <sup>2</sup>	109	164	164	246	328
Volumen interior	dm <sup>3</sup>	42	63	62	93	123
Motoventiladores 400V/III/50Hz 1.300 r.p.m.	Nº x Ø	2 x 710	2 x 710	3 x 710	3 x 710	4 x 710
	A	16,4	16,4	24,6	24,6	32,8
	kW	8	8	12	12	16
Desescarche Eléctrico	Bandeja num.	2	2	2	2	2
	Batería num.	6	10	6	10	10
	Total	8	12	8	12	12
	Potencia W	16.000	24.000	24.000	36.000	48.000
Conexiones mm.	Entrada	22	28	28	2x28	2x28
	Salida	54	66	66	2x66	2x66
Peso neto	Kg.	289	345	425	507	648
Sin Desescarche	€	<b>11.270</b>	<b>12.650</b>	<b>16.020</b>	<b>17.820</b>	<b>23.260</b>
	Código	<b>EV6570</b>	<b>EV6571</b>	<b>EV6572</b>	<b>EV6573</b>	<b>EV6574</b>
Desescarche Eléctrico	€	<b>11.807</b>	<b>13.420</b>	<b>16.715</b>	<b>18.816</b>	<b>24.408</b>
	Código	<b>EV6580</b>	<b>EV6581</b>	<b>EV6582</b>	<b>EV6583</b>	<b>EV6584</b>

PASO DE ALETAS: 12 mm.

**R-404A**

Modelo		TTX 1600	TTX 2200	TTX 2450	TTX 3400	TTX 5300
0 Pa - Capacidad $\Delta T_1 = 8K-W$ (ENV 328 cond. 2)		28.080	39.440	42.120	59.160	78.880
Caudal de aire	m <sup>3</sup> /h	49.600	48.600	74.400	72.900	97.200
250 Pa*-Capacidad $\Delta T_1 = 8K-W$ (ENV 328 cond. 2)		24.800	34240	37.200	51.360	68.480
Caudal de aire	m <sup>3</sup> /h	37.400	36.000	56.100	54.000	72.000
Superficie	m <sup>2</sup>	103	154	154	231	308
Volumen interior	dm <sup>3</sup>	53	79	78	117	154
Motoventiladores 400V/III/50Hz 1.300 r.p.m.	Nº x Ø	2 x 710	2 x 710	3 x 710	3 x 710	4 x 710
	A	16,4	16,4	24,6	24,6	32,8
	kW	8	8	12	12	16
Desescarche Eléctrico	Bandeja num.	2	2	2	2	2
	Batería num.	6	10	6	10	10
	Total	8	12	8	12	12
	Potencia W	16.000	24.000	24.000	36.000	48.000
Conexiones mm.	Entrada	22	22	28	28	2x22
	Salida	54	54	66	66	2x54
Peso neto	Kg.	293	352	433	516	660
Sin Desescarche	€	<b>11.280</b>	<b>12.720</b>	<b>16.250</b>	<b>18.160</b>	<b>23.460</b>
	Código	<b>EV6590</b>	<b>EV6591</b>	<b>EV6592</b>	<b>EV6593</b>	<b>EV6594</b>
Desescarche Eléctrico	€	<b>11.817</b>	<b>13.490</b>	<b>16.945</b>	<b>19.156</b>	<b>24.608</b>
	Código	<b>EV6600</b>	<b>EV6601</b>	<b>EV6602</b>	<b>EV6603</b>	<b>EV6604</b>

250 Pa\* - Pérdida de carga del aire en la cámara.

La capacidad indicada corresponde a la potencia sensible del evaporador (superficie seca).



EVAPORADORES INDUSTRIALES DE PLAFÓN - SERIE TT

Ø 630

Ø 710

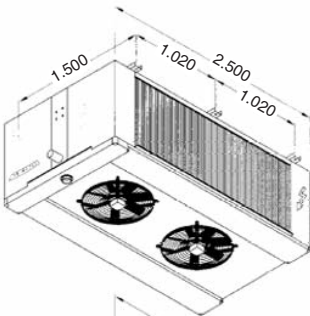

TTM-2.440/3.000  
TTB-1.650/2.350  
TTL-1.500/2.150  
TTX-1.250/1.750

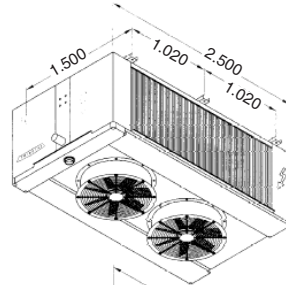

TTM-2.550/3.850  
TTB-2.100/3.100  
TTL-1.700/2.650  
TTX-1.600/2.200

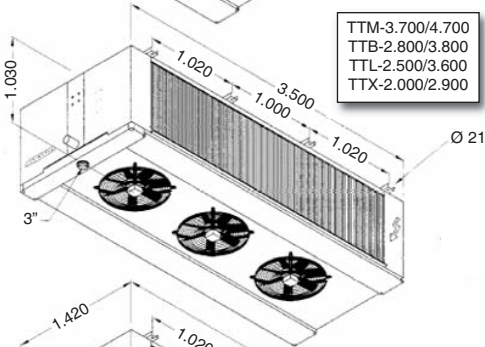

TTM-3.700/4.700  
TTB-2.800/3.800  
TTL-2.500/3.600  
TTX-2.000/2.900

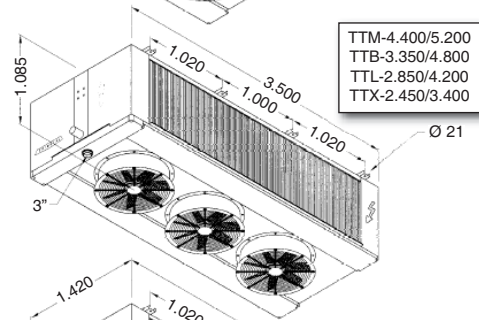

TTM-4.400/5.200  
TTB-3.350/4.800  
TTL-2.850/4.200  
TTX-2.450/3.400

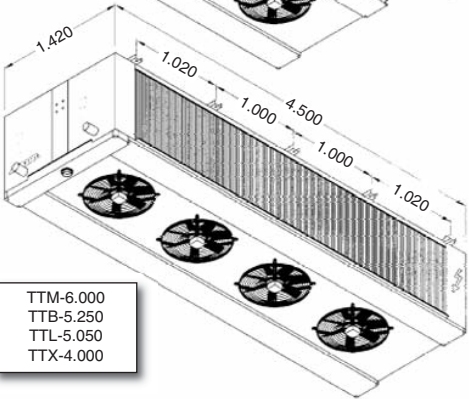

TTM-6.000  
TTB-5.250  
TTL-5.050  
TTX-4.000

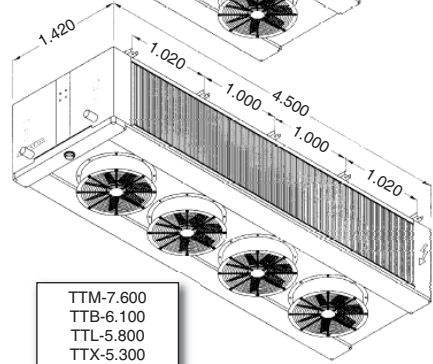

TTM-7.600  
TTB-6.100  
TTL-5.800  
TTX-5.300